

Molex 22287362 PDF

深圳创唯电子有限公司

<http://www.molex-connect.com>

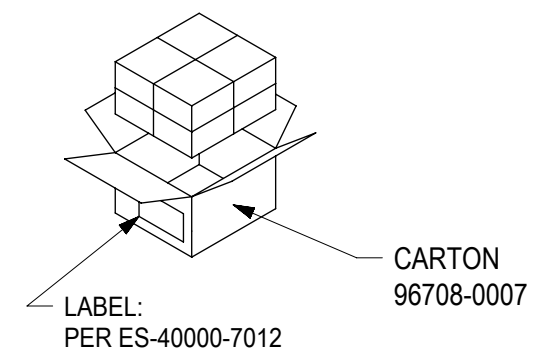

96708-0007 CARTON
HOLDS 8
96707-0012 INNER BOXES

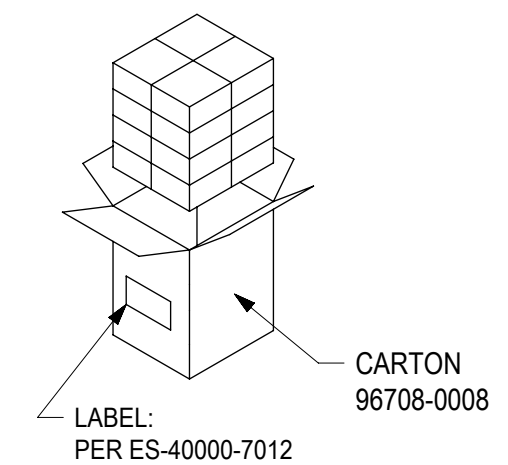

96708-0008 CARTON
HOLDS 16
96707-0012 INNER BOXES

CIRCUITS 2-28

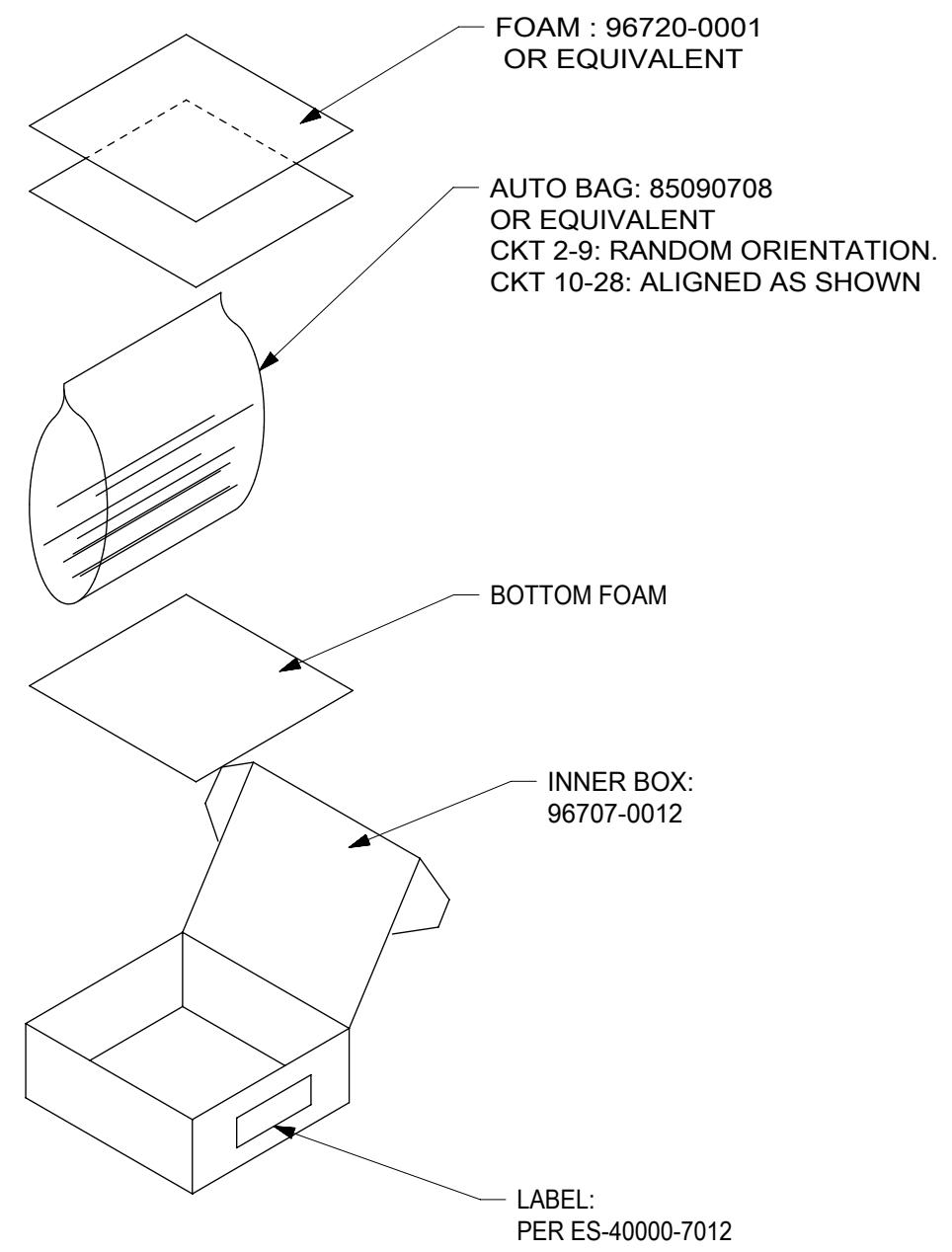

CIRCUITS 29-36

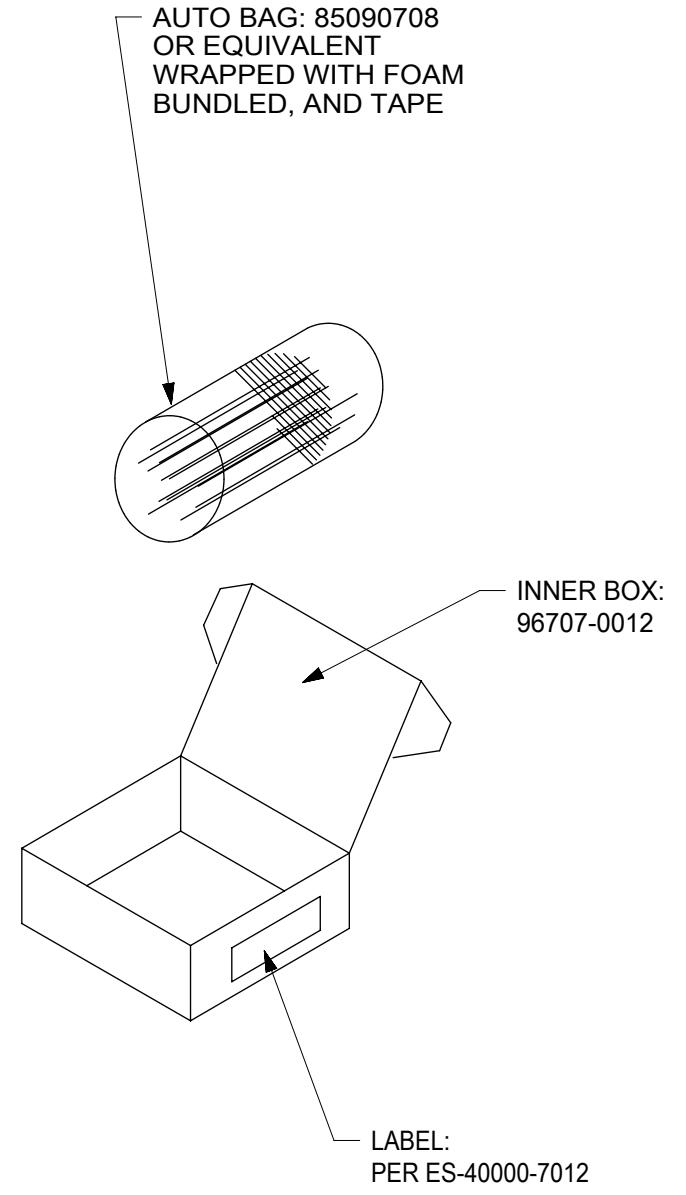

- NOTES:
1. BAGS ARE HEAT SEALED WITH AUTO BAGGER.
 2. LAYER PACK:
CKTS 2-28: WITH FOAM
CKTS 29-36: WRAP WITH FOAM, BUNDLE AND TAPE
 3. ENOUGH FOAM SHOULD BE ADDED TO EACH BOX TO PREVENT PARTS FROM RATTLING.
 4. THIS PACKAGING DOES NOT APPLY TO P/N'S 42377-0955 THRU 42377-0962. SEE "SPECIAL PACKAGING FOR MAT'L NO'S 42377-0955 / -0962".

THIS DRAWING CONTAINS INFORMATION THAT IS PROPRIETARY TO MOLEX ELECTRONIC TECHNOLOGIES, LLC AND SHOULD NOT BE USED WITHOUT WRITTEN PERMISSION									
SYMBOLS		DIMENSION UNITS		SCALE		CURRENT REV DESC: DRAWING UPDATION			
▽ = 0	IN/MM	NTS				molex			
▽ = 0	GENERAL TOLERANCES (UNLESS SPECIFIED)					PACKAGING SPEC. .100/(2.54) BREAKAWAYS			
▽ = 0		MM	INCH			PACKAGING DESIGN DRAWING			
▽ = 0	4 PLACES ±					EC NO: 612141			
▽ = 0	3 PLACES ±					DRWN: SS06 2019/01/29			
▽ = 0	2 PLACES ±					CHK'D: ISHWARG 2019/02/15			
▽ = 0	1 PLACE ±					APPR: ISHWARG 2019/02/15			
□ = 0	0 PLACES ±					INITIAL REVISION:			
■ = 0	ANGULAR TOL ± °					DRWN: JJS 1989/03/27			
▽ = 0	DRAFT WHERE APPLICABLE MUST REMAIN WITHIN DIMENSIONS		THIRD ANGLE PROJECTION		DRAWING		SERIES		MATERIAL NUMBER
					B-SIZE	40873	NA	GENERAL MARKET	1 OF 2

CKTS	42375					42376					42377/46006 SEE NOTE 4				
	PARTS PER BAG	BAGS PER INNER BOX	PARTS PER INNER BOX	PARTS PER MASTER CARTON 96708-0007 DU	PARTS PER MASTER CARTON 96708-0008 DU	PARTS PER BAG	BAGS PER INNER BOX	PARTS PER INNER BOX	PARTS PER MASTER CARTON 96708-0007 DU	PARTS PER MASTER CARTON 96708-0008 DU	PARTS PER BAG	BAGS PER INNER BOX	PARTS PER INNER BOX	PARTS PER MASTER CARTON 96708-0007 DU	PARTS PER MASTER CARTON 96708-0008 DU
2	1250	3	3750	30000	60000	1250	3	3750	30000	60000	1250	3	3750	30000	60000
3	1250	3	3750	30000	60000	1250	3	3750	30000	60000	1250	3	3750	30000	60000
4	1000	3	3000	24000	48000	1000	3	3000	24000	48000	1000	3	3000	24000	48000
5	500	3	1500	12000	24000	500	3	1500	12000	24000	500	3	1500	12000	24000
6	500	3	1500	12000	24000	500	3	1500	12000	24000	500	3	1500	12000	24000
7	500	3	1500	12000	24000	500	3	1500	12000	24000	500	3	1500	12000	24000
8	250	3	750	6000	12000	250	3	750	6000	12000	250	3	750	6000	12000
9	250	3	750	6000	12000	250	3	750	6000	12000	250	3	750	6000	12000
10	250	3	750	6000	12000	250	3	750	6000	12000	250	3	750	6000	12000
11	250	3	750	6000	12000	250	3	750	6000	12000	250	3	750	6000	12000
12	250	3	750	6000	12000	250	3	750	6000	12000	250	3	750	6000	12000
13	250	3	750	6000	12000	250	3	750	6000	12000	250	3	750	6000	12000
14	250	3	750	6000	12000	125	3	375	3000	6000	250	3	750	6000	12000
15	250	3	750	6000	12000	75	3	225	1800	3600	250	3	750	6000	12000
16	250	3	750	6000	12000	75	3	225	1800	3600	250	3	750	6000	12000
17	125	3	375	3000	6000	75	3	225	1800	3600	125	3	375	3000	6000
18	125	3	375	3000	6000	75	3	225	1800	3600	125	3	375	3000	6000
19	125	3	375	3000	6000	75	3	225	1800	3600	125	3	375	3000	6000
20	125	3	375	3000	6000	75	3	225	1800	3600	125	3	375	3000	6000
21	125	3	375	3000	6000	75	3	225	1800	3600	125	3	375	3000	6000
22	125	3	375	3000	6000	75	3	225	1800	3600	125	3	375	3000	6000
23	125	3	375	3000	6000	75	3	225	1800	3600	125	3	375	3000	6000
24	125	3	375	3000	6000	75	3	225	1800	3600	125	3	375	3000	6000
25	125	3	375	3000	6000	75	3	225	1800	3600	125	3	375	3000	6000
26	125	3	375	3000	6000	75	3	225	1800	3600	125	3	375	3000	6000
27	125	3	375	3000	6000	75	3	225	1800	3600	125	3	375	3000	6000
28	125	3	375	3000	6000	75	3	225	1800	3600	125	3	375	3000	6000
29	125	2	250	2000	4000	75	3	225	1800	3600	125	2	250	2000	4000
30	125	2	250	2000	4000	75	3	225	1800	3600	125	2	250	2000	4000
31	125	2	250	2000	4000	75	3	225	1800	3600	125	2	250	2000	4000
32	125	2	250	2000	4000	75	3	225	1800	3600	125	2	250	2000	4000
33	125	2	250	2000	4000	75	3	225	1800	3600	125	2	250	2000	4000
34	125	2	250	2000	4000	75	3	225	1800	3600	125	2	250	2000	4000
35	125	2	250	2000	4000	75	3	225	1800	3600	125	2	250	2000	4000
36	125	2	250	2000	4000	75	3	225	1800	3600	125	2	250	2000	4000

SPECIAL PACKAGING FOR MAT'L NO'S 42377-0955/-0962					
CKTS	PARTS PER BAG	BAGS PER INNER BOX	PARTS PER INNER BOX	PARTS PER MASTER CARTON 96708-0007 DU	PARTS PER MASTER CARTON 96708-0008 DU
29	75	2	150	1200	2400
30	75	2	150	1200	2400
31	75	2	150	1200	2400
32	75	2	150	1200	2400
33	75	2	150	1200	2400
34	75	2	150	1200	2400
35	75	2	150	1200	2400
36	75	2	150	1200	2400

SYMBOLS = 0 = 0 = 0 = 0 = 0 = 0 = 0 = 0	THIS DRAWING CONTAINS INFORMATION THAT IS PROPRIETARY TO MOLEX ELECTRONIC TECHNOLOGIES, LLC AND SHOULD NOT BE USED WITHOUT WRITTEN PERMISSION DIMENSION UNITS: IN/MM SCALE: NTS	CURRENT REV DESC: DRAWING UPDATION EC NO: 612141 DRWN: SS06 CHK'D: ISHWARG APPR: ISHWARG	 PACKAGING SPEC. .100/(2.54) BREAKAWAYS PACKAGING DESIGN DRAWING																			
	GENERAL TOLERANCES (UNLESS SPECIFIED) <table border="1"> <tr><td></td><td>MM</td><td>INCH</td></tr> <tr><td>4 PLACES</td><td>±</td><td>±</td></tr> <tr><td>3 PLACES</td><td>±</td><td>±</td></tr> <tr><td>2 PLACES</td><td>±</td><td>±</td></tr> <tr><td>1 PLACE</td><td>±</td><td>±</td></tr> <tr><td>0 PLACES</td><td>±</td><td>±</td></tr> </table>			MM	INCH	4 PLACES	±	±	3 PLACES	±	±	2 PLACES	±	±	1 PLACE	±	±	0 PLACES	±	±	2019/01/29 2019/02/15 2019/02/15	DOCUMENT NUMBER: PK-40873-0041 DOC TYPE: PDD DOC PART: 001 REVISION: H3
		MM		INCH																		
	4 PLACES	±		±																		
3 PLACES	±	±																				
2 PLACES	±	±																				
1 PLACE	±	±																				
0 PLACES	±	±																				
ANGULAR TOL: ± ° DRAFT WHERE APPLICABLE MUST REMAIN WITHIN DIMENSIONS	INITIAL REVISION: DRWN: JJS APPR: LENZ	1989/03/27 1989/03/27	MATERIAL NUMBER: NA CUSTOMER: GENERAL MARKET SHEET NUMBER: 2 OF 2																			
THIRD ANGLE PROJECTION:	DRAWING: B-SIZE SERIES: 40873																					

molex PRODUCT SPECIFICATION

1.0 SCOPE

This Product Specification covers the 2.54 mm (.100 inch) centerline (pitch) 0.64 mm (.025) square pin headers when mated with either printed circuit board (PCB) connectors or connectors terminated with 22 to 30 AWG wire using crimp technology.

2.0 PRODUCT DESCRIPTION

2.1 PRODUCT NAME AND SERIES NUMBERS

Crimp Terminals: 2759, 6459, 41572, 4809, 8088

Crimp Housings: 2695

PCB Connectors: 4455

Headers: 4030, 4094, 6373, 7478, 6410, 7395, 42225, 42226, 42227, 42228, 42375, 42376, 42377

Other products conforming to this specification are noted on the individual drawings.

2.2 DIMENSIONS, MATERIALS, PLATINGS AND MARKINGS

Terminal Material: Brass or Phos. Bronze (for Max performance use phos. bronze material.)

Housing: Nylon or Polyester

Pins: Brass or Phos. Bronze

For more information on dimensions, materials, and plating see the individual drawings.

2.3 SAFETY AGENCY APPROVALS

UL File Number E29179

CSALR19980

SERIES	Agency Voltage Rating (AC RMS or DC)		Agency Current Rating (Single Circuit) (Amps)		Agency Temperature Rating (°C)
	UL	CSA	UL	CSA	UL
2695	500 V AC 600 V DC	250	-	2.5	105°C
4455	600	250	-	2.5	105°C
4030	600	250	-	2.5	105°C
4094	600	250	-	2.5	105°C
6373	600	250	-	2.5	105°C
7478	600	250	-	2.5	105°C
6410	600	250	-	2.5	105°C
7395	600	250	-	2.5	105°C
42225	600	250	-	2.5	105°C
42226	600	250	-	2.5	105°C
42227	600	250	-	2.5	105°C
42228	600	250	-	2.5	105°C
42375	600	250	-	2.5	120°C
42376	600	250	-	2.5	120°C
42377	600	250	-	2.5	120°C

REVISION: T2	ECM INFORMATION: ECM No: 604532 DATE: 17/09/2018	TITLE: PRODUCT SPECIFICATION .100 CENTER KK CONNECTORS	SHEET No. 1 of 6
DOCUMENT NUMBER: PS-10-07	CREATED / REVISED BY: SS06	CHECKED BY: SS06	APPROVED BY: ISHWARG

molex PRODUCT SPECIFICATION

3.0 APPLICABLE DOCUMENTS AND SPECIFICATIONS

None

4.0 RATINGS

4.1 VOLTAGE

500 Volts AC (or 600 Volts DC)

4.2 CURRENT AND APPLICABLE WIRES (Current is dependent on connector size, contact material, plating, ambient temperature, printed circuit board characteristics and related factors. Actual current rating is application dependent and should be evaluated for each application.)

AWG	Amps (Max)	Outside Insulation Diameter
22	4.00	See Drawings
24	3.75	See Drawings
26	3.50	See Drawings
28	3.00	See Drawings
30	2.50	See Drawings

Note: current ratings are for a single circuit, based on not exceeding 30°C temperature rise.

4.3 TEMPERATURE (ambient +30°C temp)

	Brass Terminals	Phos Bronze Terminals
Operating Temperature	-40°C to +80°C*	-40°C to +105°C*
Non-Operating Temperature	-40°C to +105°C**	-40°C to +105°C

*including terminal temperature rise.

**parts not mated

REVISION: T2	ECM INFORMATION: ECM No: 604532 DATE: 17/09/2018	TITLE: PRODUCT SPECIFICATION .100 CENTER KK CONNECTORS	SHEET No. 2 of 6
DOCUMENT NUMBER: PS-10-07	CREATED / REVISED BY: SS06	CHECKED BY: SS06	APPROVED BY: ISHWARG

molex PRODUCT SPECIFICATION

5.0 PERFORMANCE

5.1 ELECTRICAL REQUIREMENTS

DESCRIPTION	TEST CONDITION	REQUIREMENT
Contact Resistance (Low Level)	Mate connectors: apply a maximum voltage of 20 mV and a current of 100 mA.	10 milliohms MAXIMUM [initial]
Contact Resistance of Wire Termination (Low Level)	Terminate the applicable wire to the terminal and measure wire using a voltage of 20 mV and a current of 100 mA.	2 milliohms MAXIMUM [initial]
Insulation Resistance	Unmate & unmount connectors: apply a voltage of 500 VDC between adjacent terminals and between terminals to ground.	1000 Megohms MINIMUM
Dielectric Withstanding Voltage	Unmate connectors: apply a voltage of {two times the rated voltage plus 1000 volts} VAC for 1 minute between adjacent terminals and between terminals to ground.	No breakdown
Capacitance	Measure between adjacent terminals at 1 MHz.	2 picofarads MAXIMUM
Temperature Rise (via Current Cycling)	Mate connectors: measure the temperature rise at the rated current after: 1) 96 hours (steady state) 2) 240 hours (45 minutes ON and 15 minutes OFF per hour) 3) 96 hours (steady state)	Temperature rise: +30°C MAXIMUM

REVISION: T2	ECM INFORMATION: ECM No: 604532 DATE: 17/09/2018	TITLE: PRODUCT SPECIFICATION .100 CENTER KK CONNECTORS	SHEET No. 3 of 6
DOCUMENT NUMBER: PS-10-07	CREATED / REVISED BY: SS06	CHECKED BY: SS06	APPROVED BY: ISHWARG

molex PRODUCT SPECIFICATION

5.2 MECHANICAL REQUIREMENTS

DESCRIPTION	TEST CONDITION	REQUIREMENT		
Connector Mate and Unmate Forces	Per circuit when mated to an .025 Sq. pin header without friction lock. Mate and unmate connector (male to female) at a rate of 25 ± 6 mm ($1 \pm \frac{1}{4}$ inch) per minute.	4.9 N (1.1 lbf) MAXIMUM insertion force & 0.56 N (0.125 lbf) MINIMUM withdrawal force		
Connector Mate and Unmate Forces 46856 series only	Per circuit when mated to a .093 thick PCB Mate and unmate connector at a rate of 25 ± 6 mm ($1 \pm \frac{1}{4}$ inch) per minute.	6.67 N (1.5 lbf) MAXIMUM insertion force & 0.56 N (0.125 lbf) MINIMUM withdrawal force		
Terminal Retention Force (in Housing)	Axial pullout force on the terminal in the housing at a rate of 25 ± 6 mm ($1 \pm \frac{1}{4}$ inch) per minute. (Forces will change with platings and materials.)	17.8 N (4.0 lbf) MINIMUM withdrawal force		
Terminal Insertion Force (into Housing)	Apply an axial insertion force on the terminal at a rate of 25 ± 6 mm ($1 \pm \frac{1}{4}$ inch) per minute. (Forces will change with platings and materials.)	11.12 N (2.5 lbf) MAXIMUM insertion force		
Durability	Mate connectors up to 25 cycles at a maximum rate of 10 cycles per minute prior to Environmental Tests.	10 milliohms MAXIMUM (change from initial)		
Vibration (Sine)	Mate connectors and vibrate per EIA 364-28, test condition I.	10 milliohms MAXIMUM (change from initial) & Discontinuity < 1 microsecond		
Shock (Mechanical)	Mate connectors and shock at 50 g's with $\frac{1}{2}$ sine wave (11 milliseconds) shocks in the $\pm X, \pm Y, \pm Z$ axes (18 shocks total).	10 milliohms MAXIMUM (change from initial) & Discontinuity < 1 microsecond		
Wire Pullout Force (Axial)	Apply an axial pullout force on the wire at a rate of 25 ± 6 mm ($1 \pm \frac{1}{4}$ inch) per minute. (For maximum performance use Molex application tooling with stranded tinned copper wire)	Wire pullout force depends on crimp tooling. See relevant Molex Application Tooling Specification for requirements.		
Normal Force	Apply a perpendicular force.	2.94 N (300 grams) average		
Kinked PC Pin Insertion Force (into PCB Hole)	Apply an axial insertion force on pins at a rate of 25 ± 6 mm ($1 \pm \frac{1}{4}$ inch) per minute.	Number of kinked pins	Maximum Insertion force (per pin)	Average Insertion force (per pin)
		2	44.0 N (9.9 lbf)	15.1N (3.4 lbf)
		4	21.4 N (4.8 lbf)	9.8 N (2.2 lbf)
		6	18.2 N (4.1 lbf)	4.9 N (1.1 lbf)

REVISION:	ECM INFORMATION:	TITLE:	SHEET No.
T2	ECM No: 604532 DATE: 17/09/2018	PRODUCT SPECIFICATION .100 CENTER KK CONNECTORS	4 of 6
DOCUMENT NUMBER:	CREATED / REVISED BY:	CHECKED BY:	APPROVED BY:
PS-10-07	SS06	SS06	ISHWARG

molex PRODUCT SPECIFICATION

5.3 ENVIRONMENTAL REQUIREMENTS

DESCRIPTION	TEST CONDITION	REQUIREMENT										
Shock (Thermal)	Mate connectors; expose to 5 cycles of: <table border="1"> <thead> <tr> <th>Temperature °C</th> <th>Duration (Minutes)</th> </tr> </thead> <tbody> <tr> <td>-40 +0/-3</td> <td>30</td> </tr> <tr> <td>+25 ±10</td> <td>5 MAXIMUM</td> </tr> <tr> <td>+105 +3/-0</td> <td>30</td> </tr> <tr> <td>+25 ±10</td> <td>5 MAXIMUM</td> </tr> </tbody> </table>	Temperature °C	Duration (Minutes)	-40 +0/-3	30	+25 ±10	5 MAXIMUM	+105 +3/-0	30	+25 ±10	5 MAXIMUM	10 milliohms MAXIMUM (change from initial) & Visual: No Damage
Temperature °C	Duration (Minutes)											
-40 +0/-3	30											
+25 ±10	5 MAXIMUM											
+105 +3/-0	30											
+25 ±10	5 MAXIMUM											
Thermal Aging	Mate connectors; expose to: 96 hours at 105 ± 2°C	10 milliohms MAXIMUM (change from initial) & Visual: No Damage										
Humidity (Steady State)	Mate connectors: expose to a temperature of 40 ± 2°C with a relative humidity of 90-95% for 96 hours. Note: Remove surface moisture and air dry for 1 hour prior to measurements.	10 milliohms MAXIMUM (change from initial) & Dielectric Withstanding Voltage: No Breakdown at 500 VAC & Insulation Resistance: 1000 Megohms MINIMUM & Visual: No Damage										
Humidity (Cyclic)	Mate connectors: cycle per EIA-364-31: 24 cycles at temperature 25 ± 3°C at 80 ± 5% relative humidity and 65 ± 3°C at 50 ± 5% relative humidity; dwell time of 1.0 hour; ramp time of 0.5 hours. {Note: Remove surface moisture and air dry for 1 hour prior to measurements.}	10 milliohms MAXIMUM (change from initial) & Dielectric Withstanding Voltage: No Breakdown at 500 VAC & Insulation Resistance: 1000 Megohms MINIMUM & Visual: No Damage										
Solderability	Per SMES-152	Solder coverage: 95% MINIMUM (per SMES-152)										

REVISION: T2	ECM INFORMATION: ECM No: 604532 DATE: 17/09/2018	TITLE: PRODUCT SPECIFICATION .100 CENTER KK CONNECTORS	SHEET No. 5 of 6
DOCUMENT NUMBER: PS-10-07	CREATED / REVISED BY: SS06	CHECKED BY: SS06	APPROVED BY: ISHWARG

molex PRODUCT SPECIFICATION

5.3 ENVIRONMENTAL REQUIREMENTS

DESCRIPTION	TEST CONDITION	REQUIREMENT
Solder Resistance	Dip connector terminal tails in solder: Solder Duration: 5 ± 0.5 seconds; Solder Temperature: $230 \pm 5^\circ\text{C}$	Visual: No Damage to insulator material
Cold Resistance	Mate connectors: Duration: 96 hours; Temperature: $-40 \pm 3^\circ\text{C}$	10 milliohms MAXIMUM (change from initial) & Visual: No Damage
Corrosive Atmosphere: Flowing Mixed Gas (FMG)	Test per EIA-364-65, Class II, Exposure to gasses for 4 days, unmated.	10 milliohms MAXIMUM (change from initial) & Visual: No Damage

6.0 PACKAGING

Parts shall be packaged to protect against damage during handling, transit and storage.

7.0 GAGES AND FIXTURES

8.0 OTHER

REVISION: T2	ECM INFORMATION: ECM No: 604532 DATE: 17/09/2018	TITLE: PRODUCT SPECIFICATION .100 CENTER KK CONNECTORS	SHEET No. 6 of 6
DOCUMENT NUMBER: PS-10-07	CREATED / REVISED BY: SS06	CHECKED BY: SS06	APPROVED BY: ISHWARG